

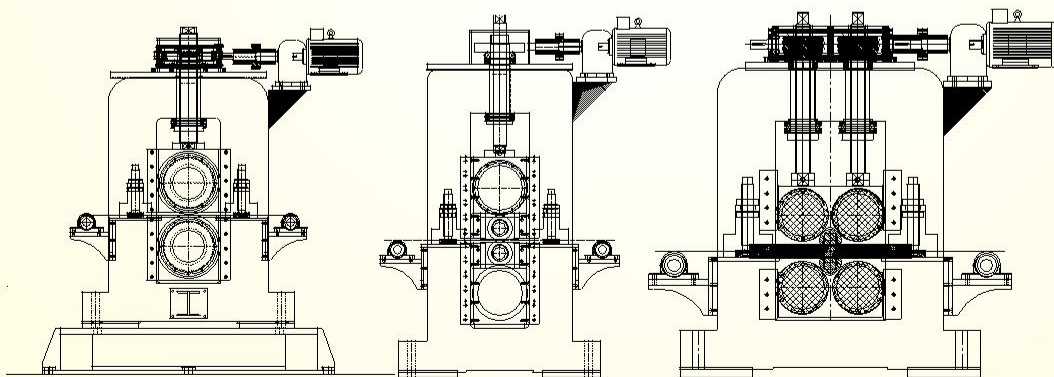

VSR





Page No	Content
1	Index
2	About Us
3	Company Details
4	Product Range, Other Machinery Parts
5	Cold Rolling Mills For Sheet , Coils & Strip
6	2 Hi Cold Rolling Mill
7	4 Hi Cold Rolling Mill
8	4 Hi Cold Rolling Mill
9	6 Hi Cold Rolling Mill
10	6 Hi Cold Rolling Mill
11	Tandem Rolling Mills (4 Stand , 6 Stand, 8 Stand)
12	Tandem Rolling Mills (4 Stand , 6 Stand, 8 Stand)
13	Hot Rolling Mills
14	Product Specification of Hot Rolling Mills
15	2 Hi Hot Rolling Mill Reversible
16	2 Hi Hot Rolling Mill Reversible
17	3 Hi Hot Rolling Mill
18	5 Hi Hot Rolling Mill
19	Reheating Furnace
20	2 Hi Hot Rolling Mill Non Reversible Flywheel
21	Wider Wide Slitting Machine
22	Wider Wide Slitting Machine
23	Narrow width Slitting Machine
24	Side Trimming Slitting Machine
25	Annealing Furnace
26	Annealing Furnace
27	Bell Type Annealing Furnace
28	Pickling Line (De-Greasing lines) & Acid Regeneration Plant
29	Straightening Machine (Tapper Roll)
30	Straightening Machine with cut to length Line
31	Multi-Roll Leveller Cum Straightening Machine
32	Scalping Cum Milling Machine
33	Draw Benches
34	Rolling Mill Parts And Allied Products
35	Rolling Mill Parts And Allied Products
36	Rolling Mill Parts And Allied Products
37	Our Manufacturing Plant
38	Annual Maintenance Contract
39	Process Flow Chart
40	Our Company's Infrastructure & Machines

ABOUT US

VSR Rolling Mills & Machinery Private Limited is an ISO 9001:2015 certified company and a Government of India Recognized EXPORT & Domestic House. Situated in Indore, Madhya Pradesh, India, our well-equipped engineering company is located at 9/1, 9/2, Bardaji Repti Rang Sanwer Road, Indore-462003, 462005, 462006, 462007, 462008, 462009, 462010, 462011, 462012, 462013, 462014, 462015, 462016, 462017, 462018, 462019, 462020, 462021, 462022, 462023, 462024, 462025, 462026, 462027, 462028, 462029, 462030, 462031, 462032, 462033, 462034, 462035, 462036, 462037, 462038, 462039, 462040, 462041, 462042, 462043, 462044, 462045, 462046, 462047, 462048, 462049, 462050, 462051, 462052, 462053, 462054, 462055.

Since our establishment in 2010, VSR Rolling Mills & Machinery Private Limited has been a distinguished manufacturer, exporter, and supplier of capital equipment, metal processing rolling mills and allied equipment. Our products adhere to international standards and are customized to meet the specific requirements of our clients. These machines are known for their corrosion resistance, high performance, and durability, making them highly popular in the industry. Additionally, we offer efficient engineering consultancy services to our clients.

Catering to the needs of the copper, aluminium, and steel mill industry, our services encompass engineering consultancy, design and development, manufacturing, and exporting of high economical and cost-effective copper/aluminium rolling mill plants on a turnkey basis. With a machining and material handling capacity of up to 10 M.T., we provide comprehensive engineering assistance to the entire copper/aluminium/steel making industry.

Under the prudent leadership of Mr. Ravi Kumar Bankhede, VSR Rolling Mills & Machinery Private Limited is a professionally managed company. Our technical experts, who have worked with some of India's largest organizations and machine shops, collaborate as an interactive team, bringing their expertise to a new excellence. We believe in establishing enduring partnerships with our customers, fostering stronger relationships and mutual growth.

Mr. Ravi Kumar Bankhede, the Managing Director of VS Rolling Mills & Machinery Private Limited, holds a master's degree in Finance and Business Management (MBA) and a bachelor's degree in Mechanical Engineering. With a background in mechanical engineering and a versatile experience of 10 years in metallurgy and machine shops.

Mr. Kush Raut (Managing Director) With over 12 years of experience in operations, brings extensive expertise and industry knowledge to the table. His visionary leadership and commitment to excellence have been instrumental in driving our company's success and delivering top-notch solutions to our clients.

Turn Key/Consultancy for setting up complete plant for All Metal

- Melting and casting Plant for Copper, Brass, Aluminium, Steel and Alloys
- Non Ferrous Rolling Mill Plants
- Extrusion Plant for Copper, Aluminium and steel, and their Alloy Products
- AMC Services for Rolling Mill Plants

Team Member	Designation	Experience
Ravi Kumar Bankhede	Technical Director	12 year
Kush Raut	Managing Director	12 year
Amit Pawar	Hydraulic Engineer	12 year
Anjana Bankhede	HR	3 year
Ravindra Panse	Erection and commissioning	10 year
Vivek Singh	Drawing Engineer	8 year

Nature of Business	Exporter and Manufacturer of Hot and cold Rolling mill for Ferrous and non-ferrous metal and allied equipment
Additional Business	Exporter Service Provider Importer Supplier
Company CEO	Ravi kumar Bankhede
Total Number of Employees	15 to 30 People
Year of Establishment	2010 - 2019 (Proprietor Firm) - 2019 to present Pvt. Ltd. Co.)
Trade & Market	
Export Percentage	30-50%
Team and Staff	
No. of Research / QC Staff	3 - 5 People
No. of Engineers and Technicians	8 - 10 People
No. of Skilled Staff	Above 10 People
No. of Semi-skilled Staff	Above 10 People
Company USP	
Provide after Sales Support	Operational Training User Manual
Quality Measures / Testing Facilities	Yes
Statutory Profile	
Import Export Code (IEC)	AAHCV0997P
Tan No.	BPLV04493G
GST No.	23AAHCV0997P1ZL
CIN No.	U29309MP2019PTC049600
Udyam MSME	UDYAM-MP-23-0012497

PRODUCT RANGE

Cold Rolling Mills

- ❖ 2 HI Reversible Cold Rolling mills
- ❖ 4 HI Reversible Cold Rolling mills
- ❖ 6 HI Reversible Cold Rolling mills
- ❖ Tandem Cold Rolling mill
- ❖ Skin Pass Mills

SLITTING MACHINE

- ❖ Narrow width Slitting Machine (50mm – 400mm width)
- ❖ Side Trimming Slitting Machine
- ❖ Wider width Slitting Machine (400mm – 2000mm width)

FURNACE

- ❖ Deep Annealing Furnace with pot
- ❖ Bell Annealing Furnace
- ❖ Beach Type Annealing Furnace
- ❖ Ammonia Cracker
- ❖ Reheating Furnace
- ❖ Melting Furnace
- ❖ Muffle Furnace

DRAW BENCHES

- ❖ Chain Type Draw Benches
- ❖ Hydraulic Draw Benches

Hot Rolling Mills

- ❖ 2 HI Hot Rolling mills Reversible
- ❖ 3 HI Hot Rolling mills Reversible
- ❖ 4 HI Hot Rolling mills Reversible
- ❖ 5 HI Hot Rolling mills Reversible
- ❖ Tandem Hot Rolling mill (4 – 6 – 8 stand)
- ❖ Lab Rolling Mill (Hot and Cold Rolling mill of single Housing)

STRAIGHTENING MACHINE

- ❖ Bus bar / Strips coil Straightening Machine
- ❖ Tube / Rod Straightening Machine
- ❖ Section Straightening Machine

OTHER MACHINERY

- ❖ Sheet Leveller Machine
(5 Rolls –7 Roll –9 Roll –11 Rolls)
- ❖ Cut To Length Line
- ❖ Scalping Machine
- ❖ Brushing Machine
- ❖ Pickling Line
- ❖ Degreasing Line
- ❖ Rewinding Machine
- ❖ UP – coiler
- ❖ Coiler car
- ❖ Roll changing Trolley
- ❖ Rolling mill Conveyor Table

OTHER MACHINERY PARTS

A. Hot And Cold Rolling Mill Rolls

- ❖ Work Rolls
- ❖ Backup Rolls
- ❖ TC Rolls
- ❖ Deflector Rolls
- ❖ Edge Rolls
- ❖ Guide Rolls

B) Pinion Gear Box

C) Reduction Gear Box

D) Cardon Shaft & Universal joint

E) Motor

F) ETR – Coiler & DTR – Coiler

G) UP – Coiler

H) Payoff & Un - Coiler

I) Edge Roll Unit

J) VFD – PLC – HMI

K) Control Panel

L) Remote Desk

M) Pinch Roll Unit

N) Side Roll Guide

O) Payoff Unit

P) Roll Changing Trolley

Q) Rolling Mills Parts

R) Choke

S) Manual Screw Down Automatic And Semiautomatic

T) Reduction Cum Pinion Gear Box

U) All Type Of Gear Box Customizes Ratio

V) All Types Of Die

W) All Types Of Gear Box

X) Hydraulics Power Pack

Y) Slitting Cutter

Z) Slitting Spacers

Cold Rolling Mills for Sheet, Strip & Coils

The Cold Rolling Mills are used for reducing the thickness of sheet/ strip/ coils of various metals to the desired thickness and to improve various properties like surface finish, strength, thickness tolerances and achieving required hardness like full hard, half hard, quarter hard etc. Normally, these mills are made in 4Hi, 2Hi and 6Hi configurations. The machines are designed in compliance with advanced technological standards in order to achieve better formability, finish, precise dimensions and strength of the material. Various parts of the mill like the Rolls, Housings, Gear Box, Screw Down and drive system are matched properly to give optimum performance with minimal down time in maintenance and repairs. We make the complete range of custom designed Cold Rolling Mills from simple basic sheet rolling mills to technologically advanced coil rolling mills with AGC. We have manufactured mills for variety of Ferrous and Non-Ferrous metals like Aluminium, Copper, Brass, Cupro-Nickel, Stainless Steel (202 to 304 Grade); Mild Steel, Boron Steel, Carbon Steels, Lead etc.

Product Specification of 2hi - Cold Rolling Mill

Machine Type	2HI cold rolling mill
Mil Type	Reversible / Non Reversible
Pressing Device	Manual / Mechanical Screw down / Hydraulic AGC
Input Raw Material	Ferrous and Non – Ferrous Metal
Rolled shape Material	Coils, Foils, Strips, sheet
Input thickness	12mm – 25mm maximum
Input width	50mm – 1250mm
Production capacity	15 – 30 tonnes/day
Coiler Weight Max*	1000 - 5,000kgs
Mill speed Max*	10 - 400MPM
Finished Output Thickness / Width	1.0mm – 4.00mm
Maximum inner / outer diameter of the coil	300mm - 350mm - 508mm /1500mm
Maximum rolling force	80 - 400 tonnes
Depression type	Mechanical Screw Down / Manual / Servo / Hydraulic AGC
Transmission mode	work roll / Backup Roll transmission
Roll bearing lubrication method	Grease lubrication/ Air oil Lubrication
Rack section	200 × 350
Electronic control	Siemens / Schneider / L & T
Reducer Gear box	Elecon / shanti / Self made
Motor	Siemens / BBL / ABB
Total installed capacity	As per machine specifications
Unit size	8 meter × 4 meter × 2 meter (L×W×H)

2 Hi Cold Rolling Mills

The 2Hi Cold Rolling Mill are used for rolling of sheets, plates and coils of softer metals like Aluminum, Copper, Brass, Lead etc. to higher thickness (normally above 1 mm). We have manufactured more than 200 such rolling mills ranging from 50 mm width to 2000 mm width running successfully all over India and abroad. Optimum design and raw materials machined to high accuracy help us achieve close thickness tolerance, flatness and high surface finish on rolled products. These mills can be used for breakdown rolling of thicker material and also for finish rolling.



Features

- Heavily reinforced Stand Housings machined to closest tolerances (Window Size within 0.04 mm)
- Rolls made of forged alloy steel having high hardness (62+ HRC)
- Rolls running on Spherical Roller Bearings fitted in C-45 grade steel cast housings with labyrinth sealing arrangement
- Screw Down with Bronze Nut & Buttress threaded Alloy Steel Screw – Manual – Gear motor – Servo Motor – Hydraulic AGC
- Extra heavy duty Gear Box cum Pinion Stand with hardened output shafts
- Universal type Coupling Spindles with Slipper Pads for drive from Gear Box to Rolls

Application

- Rolling mills
- Pipes and tubes industry
- Transformers
- Metal industry
- Electrical components Industry
- Copper industry
- Copper Tape foil manufacturing industry
- Wire industry
- Metal industry
- Machining industry

4 Hi Cold Rolling Mills

The 4Hi Cold Rolling Mills are used for rolling of coils, sheets and plates of all types of metals and alloys like Stainless Steel, Mild Steel, Brass, Copper, Cupro-Nickel, Aluminum etc. We have manufactured more than 400 such rolling mills running successfully all over India and abroad in countries like Brazil, Turkey, Malaysia, Nigeria, Kenya, Zambia, Tanzania etc. We can manufacture mills upto 800 mm width for harder metals like Stainless Steel and upto 1800 mm width for softer metals like Copper/ Brass/ Aluminum etc. Optimum design and raw materials machined to high accuracy help us achieve close thickness tolerance, flatness and high surface finish on rolled products.

Product Specification of 4hi - Cold Rolling Mill

Machine Type	4HI cold rolling mill
Mil Type	Reversible / Non Reversible
Pressing Device	Manual / Mechanical Screw down / Hydraulic AGC
Input Raw Material	Ferrous and Non – Ferrous Metal
Rolled shape Material	Coils, Foils, Strips, sheet
Input thickness	2.0mm – 4.0mm
Input width	50mm – 1250mm
Production capacity	15 – 30 tonnes/day
Coiler Weight Max*	1000 - 5,000kgs
Mill speed Max*	10 - 400MPM
Finished Output Thickness / Width	0.10mm – 0.50mm
Maximum inner / outer diameter of the coil	300mm - 350mm - 508mm /1500mm
Maximum rolling force	80 - 400 tonnes
Depression type	Mechanical Screw Down / Manual / Servo / Hydraulic AGC
Transmission mode	work roll / Backup Roll transmission
Roll bearing lubrication method	Grease lubrication/ Air oil Lubrication
Rack section	200 × 350
Electronic control	Siemens / Schneider / L & T
Reducer Gear box	Elecon / shanti / Self made
Motor	Siemens / BBL / ABB
Total installed capacity	As per machine specification
Unit size	8 meter × 4 meter × 2 meter (L×W×H)



Features

- Heavily reinforced Stand Housings machined to closest tolerances (Window Size within 0.04 mm)
- Back Up Rolls made of forged alloy steel having hardness in range of 54-58 HRC
- Back Up Roll running on Spherical Roller Bearings fitted in C-45 grade steel cast housings
- Work Rolls made of forged Alloy steel having high hardness of 62+ HRC as required
- Motorised worm geared Screw Down with Bronze Nut & Buttress threaded Alloy Steel Screw.
- Extra heavy duty Gear Box & Pinion Stand with hardened output shafts
- Roll removal trolley system for easy replacement of Rolls
- AGC for accurate thickness control (optional)

Application :- • Metal industry • Rolling mills

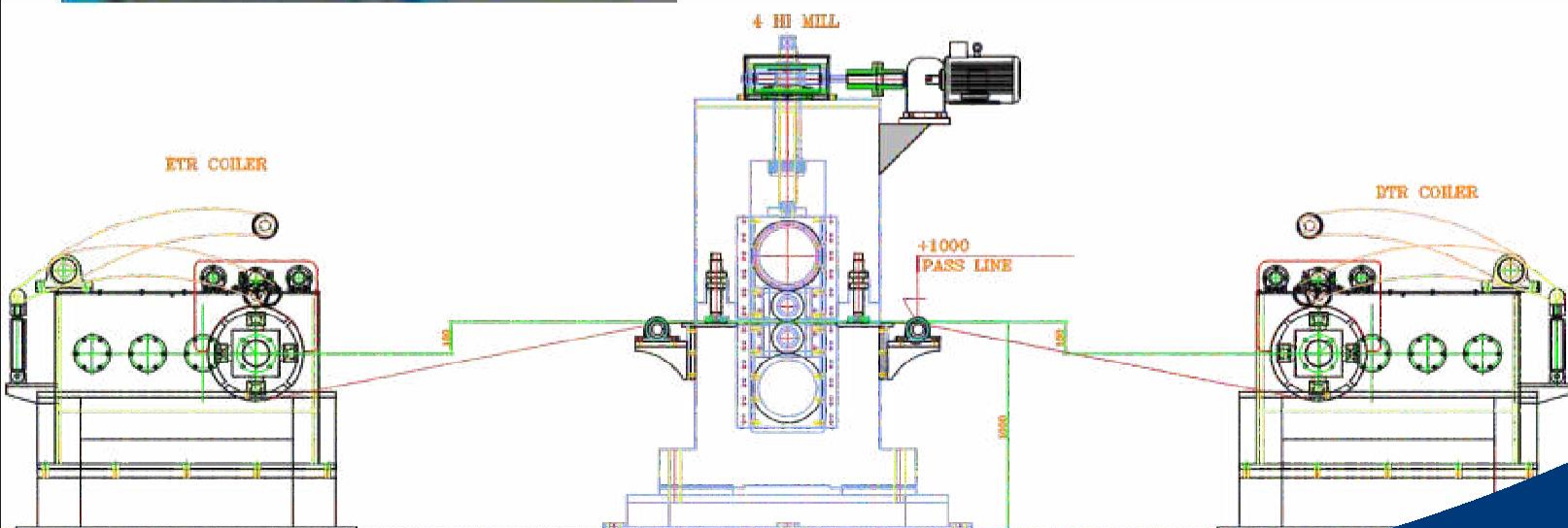

4HI COLD ROLLING MILL REVERSIBLE

6hi Cold Rolling Mills

We produce the premium nature of Cold Rolling Mills for Stainless Steel which gives great power and resilience to stainless steel products. This machine helps in improving the surface finish and tensile strength of the stainless steel coils, sheet and strips. Stainless steel formed in cold rolling mills are annealed and pickled before it is processes through skinpass mill, to ensure a smoother surface. Further, we give a uniform scratch finish by polishing with abrasive belts. We offer profiles that offers the most precise and reasonable solution for our clients desired components.

Product Specification of 6 - Cold Rolling Mill

Machine Type	6hi cold rolling mill
Mil Type	Reversible / Non Reversible
Pressing Device	Manual / Mechanical Screw down / Hydraulic AGC
Input Raw Material	Ferrous and Non – Ferrous Metal
Rolled shape Material	Coils, Foils, Strips, sheet
Input thickness	2.0mm – 4.0mm
Input width	50mm – 1250mm
Production capacity	15 – 30 tonnes/day
Coiler Weight Max*	1000 - 5,000kgs
Mill speed Max*	10 - 400MPM
Finished Output Thickness / Width	0.020mm – 0.10mm
Maximum inner / outer diameter of the coil	300mm - 350mm - 508mm /1500mm
Maximum rolling force	80 - 400 tonnes
Depression type	Mechanical Screw Down / Manual / Servo / Hydraulic AGC
Transmission mode	Backup Roll transmission
Roll bearing lubrication method	Grease lubrication/ Air oil Lubrication
Rack section	200 × 350
Electronic control	Siemens / Schneider / L & T
Reducer Gear box	Elecon / shanti / Self made
Motor	Siemens / BBL / ABB
Total installed capacity	As per machine specification
Unit size	As per machine specification(L×W×H)





Features

- Quality approved stainless steel
- Scratch resistant
- High productivity and output
- Firm built
- Minimal operating cost
- Accurate performance
- Nominal operating cost

Application :-

- Rolling mills
- Copper tape
- Copper foil 0.020mm
- Electrical components

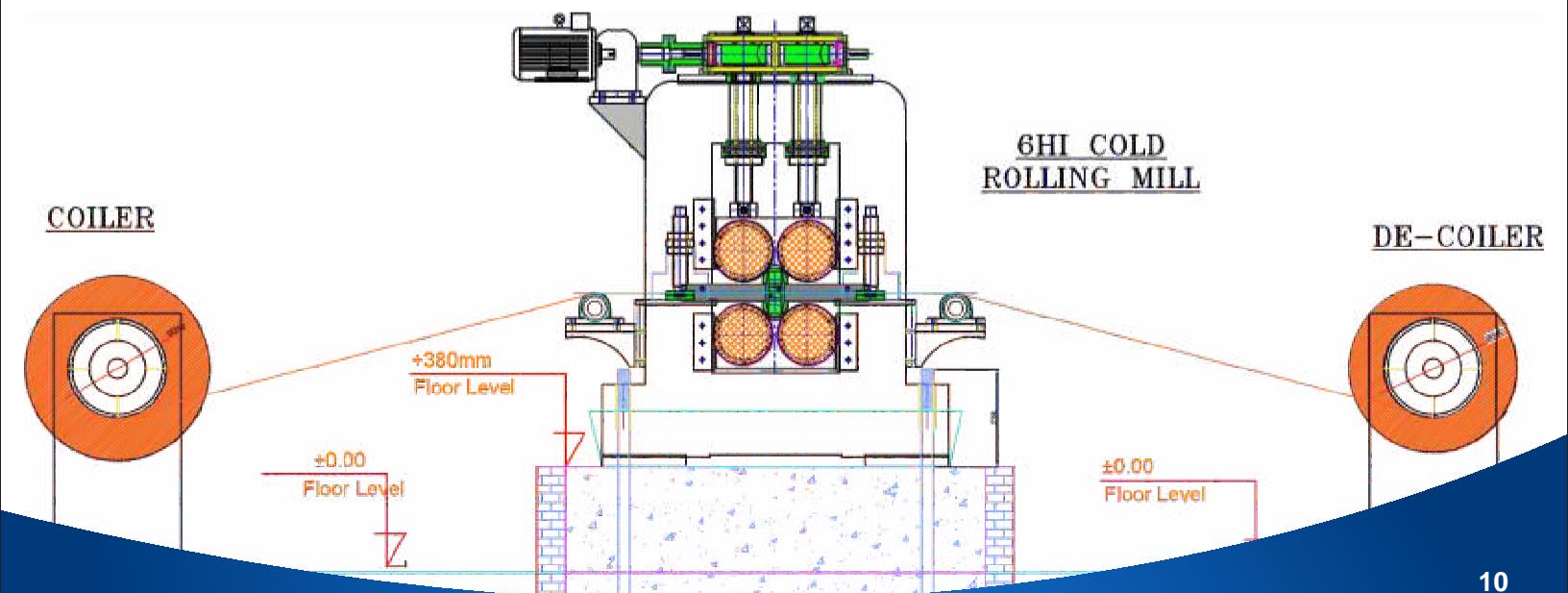

Tandem Cold Rolling Mills (4stand – 6stand – 8stand)

The Tandem Cold Rolling Mill is used mainly for breakdown rolling of thick sheets/ plates of metals like Copper, Brass and Aluminum where the weight of sheet is on the higher side. It is difficult to return such heavy sheets back to the operator after the pass so the Tandem Mill is advantageous in such scenario because it provides for reversible operation. The sheet can be fed in the mill from both sides thus reducing the handling time and effort. These mills consist of Top & Bottom Rolls of same diameter and one middle Roll of smaller diameter. The drive is give to both Top & Bottom Rolls through a combination of Gear Box “ Pinion Stand “ Coupling Spindles. Since the diameter of Work Roll is larger in this case, this mill is more suitable for rolling in thicker sheets.

Product Specification of Tandem - Cold Rolling Mill

Machine Type	Tandem cold rolling mill (4 stand – 6 stand – 8 stand)
Pressing Device	Manual / Mechanical Screw down / Hydraulic AGC
Input Raw Material	Ferrous and Non – Ferrous Metal
Rolled shape Material	Coils, Foils, Strips, sheet
Input thickness	12.0mm – 20.0mm
Input width	50mm – 1250mm
Production capacity	15 – 30 tonnes/day
Coiler Weight Max*	1000 - 5,000kgs
Mill speed Max*	10 - 200MPM
Finished Output Thickness / Width	0.10mm – 0.50mm
Maximum inner / outer diameter of the coil	300mm - 350mm - 508mm /1500mm
Maximum rolling force	80 - 400 tonnes
Depression type	Mechanical Screw Down / Manual / Servo / Hydraulic AGC
Transmission mode	work roll / Backup Roll transmission
Roll bearing lubrication method	Grease lubrication/ Air oil Lubrication
Rack section	200 × 350
Electronic control	Siemens / Schneider / L & T
Reducer Gear box	Elecon / shanti / Self made
Motor	Siemens / BBL / ABB
Total installed capacity	As per machine specification
Unit size	8 meter × 4 meter × 2 meter (L×W×H)



Features

- Heavily reinforced Stand Housings machined to closest tolerances (Window Size within 0.04 mm)
- All Rolls are made of forged alloy steel having high hardness in range of 62+ HRC
- All Rolls running on Spherical Roller Bearings fitted in C-45 grade steel cast housings
- Motorised worm geared Screw Down with Bronze Nut & Buttruss threaded Alloy Steel Screw.
- Extra heavy duty Gear Box & Pinion Stand with hardened output shafts
- Roll removal trolley system for easy replacement of Rolls

Application :-

- Rolling mills • Metal industry



HOT ROLLING MILLS

We manufacture Hot Rolling Mill for flat products like Strip, Sheet and Plate. The Hot Rolling Mills are normally of 2HI – 3HI – 4HI - 5HI and Tandem Hot Rolling Mill configuration depending on the type of product being rolled. The 2HI and 4HI Hot Rolling Mills Reversible are used for materials like Aluminium, Copper, Brass and other softer metals whereas the 3HI - 5HI and Tandem Hot Rolling Mills Non-Reversible are used for harder metals like Stainless Steel, Alloy Steel etc. where lower thicknesses are to be achieved by Hot Rolling Process.

The slabs are fed in the mill directly after casting or after re-heating of slabs as required for the specific material being rolled. The mill speed is kept optimum so as to finish the Hot rolling process well above the re-crystallisation temperature. We have manufactured 2HI Hot Rolling Mills upto slab size of 150 mm thick x 1270 mm width for Non-Ferrous metals and 5HI Hot Rolling Mills for flats/ plates upto 50 mm thick x 800 mm width for Stainless Steel.

Type of Hot Rolling mill

Hot Rolling Mills

- A) 2HI – 3HI – 4HI – 5HI & Tandem
- B) Reversible and Non Reversible with Flywheel
- C) Pressing Device
 - ❖ Manual Screw Down
 - ❖ Gear and servo Motor Screw Down
 - ❖ Hydraulic Cylinder AGC

Since the load on the drive system like Gear Box and Coupling Spindle is very high in case of Hot Rolling Mills coupled with the shock load, we take extra safety factor in consideration while designing these parts so that they can withstand the excess load and give trouble free operation for many, many years.



Product Specification of Hot Rolling Mill

Machine Type	2HI – 3HI – 4HI -5HI -TANDEM
Mil Type	Reversible / Non Reversible
Pressing Device	Manual / Mechanical Screw down / Hydraulic AGC
Input Raw Material	Stainless Steel, Mild Steel
Rolled shape	Plate / slab / Boom
Slab specification	150 x 1250 x Length*
Production capacity	15 – 50 tonnes/day
Input Thickness Max*	150mm
Input Width Max*	250mm~ 500mm
Coiler Weight Max*	1000 - 5,000kgs
Mill speed Max*	10 - 80MPM
Finished Output Thickness / Width	15mm – 17.0mm
Maximum inner / outer diameter of the coil	508mm /1300mm
Maximum rolling force	80 - 1250 tonnes
Depression type	Mechanical Screw Down
Transmission mode	work roll transmission
Roll bearing lubrication method	Grease lubrication
Rack section	400x450
Electronic control	Siemens / Schneider / L & T
Reducer Gear box	Elecon / shanti / Selfmade
Motor	Siemens / BBL / ABB
Total installed capacity	As per machine specifications
Unit size	As per machine specifications(LxWxH)

Additional Information

Delivery Time	4 months
Production Capacity	20-100 MT per day

2 Hi Hot Rolling Mill Reversible



The 2Hi Hot Rolling Mills is used for rolling of thick slabs of softer metals like Aluminium, Copper, Brass and mild steel also. We have supplied these Hot Rolling Mills to many renowned industries in India which have been running successfully since many years. We have designed and manufactured mills to take up slab thickness of upto 150 mm and width upto 1270 mm. The normal output thickness of these mill vary from 6 mm to 14 mm after which the material is fed in the Cold rolling Mills for further processing. These mills are normally driven by combination of Gear Box and Coupling Spindle drive but in some cases, the drive can be through open gear and joda gear system to economise the cost.

Features

- Extra heavy duty Gear Box and drive system
- Mechanical system for protection from overload/ human error
- Alloy Steel hardened Rolls with long life
- Rolls running on Fibre Bush/ Bearings
- Motorised Screw Down system with Bronze Nut
- Precisely balance flywheel mounted on separate shaft
- Energy efficient with Slipring Motor

Application

- Aluminum Slabs
- Copper/ Brass slabs
- Mild Steel Plates





2 HI HOT ROLLING MILL REVERSIBLE

Snubber rolls over the coil for both (tension coiler)

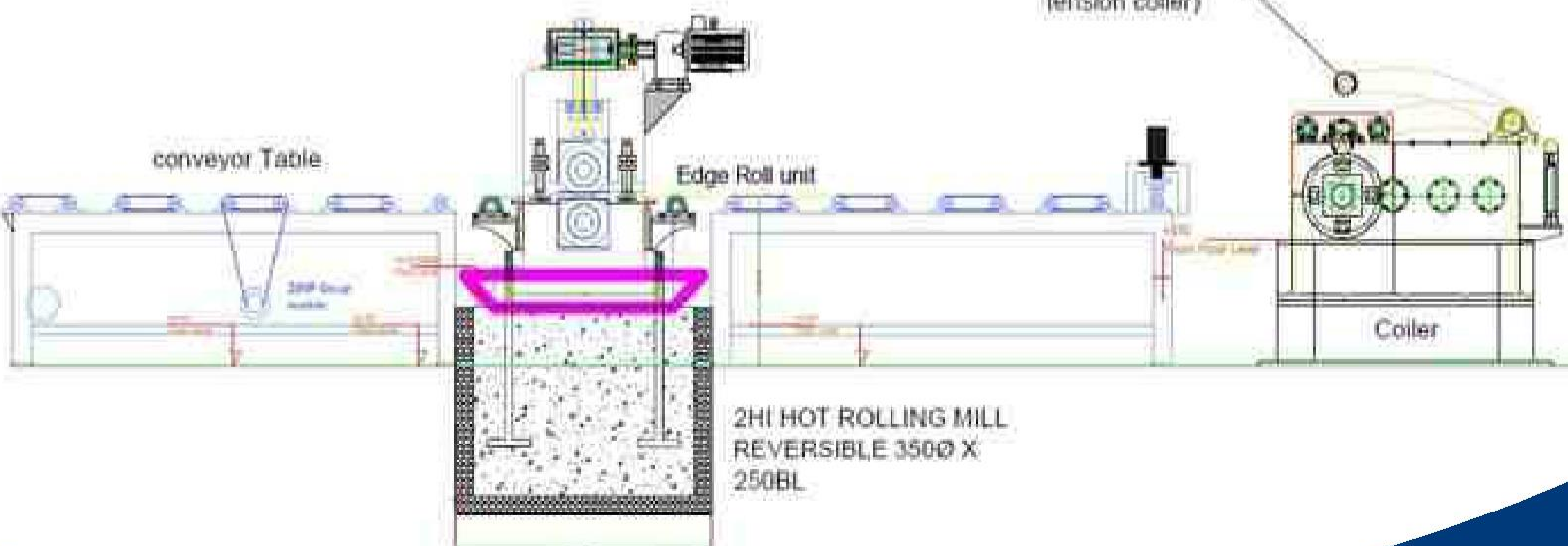

3HI HOT ROLLING MILL

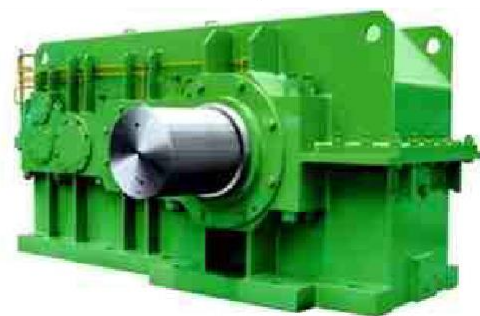

The 3Hi HOT Rolling Mill is used mainly for breakdown rolling of thick sheets/ plates of metals like Copper, Brass and Aluminum where the weight of sheet is on the higher side. It is difficult to return such heavy sheets back to the operator after the pass so the 3Hi Mill is advantageous in such scenario because it provides for reversible operation. The sheet can be fed in the mill from both sides thus reducing the handling time and effort. These mills consist of Top & Bottom Rolls of same diameter and one middle Roll of smaller diameter. The drive is given to both Top & Bottom Rolls through a combination of Gear Box “ Pinion Stand “ Coupling Spindles. Since the diameter of Work Roll is larger in this case, this mill is more suitable for rolling in thicker sheets.

Features

- Heavily reinforced Stand Housings machined to closest tolerances (Window Size within 0.04 mm)
- All Rolls are made of forged alloy steel having high hardness in range of 62+ HRC
- All Rolls running on Spherical Roller Bearings fitted in C-45 grade steel cast housings
- Motorised worm geared Screw Down with Bronze Nut & Buttress threaded Alloy Steel Screw.
- Extra heavy duty Gear Box & Pinion Stand with hardened output shafts
- Roll removal trolley system for easy replacement of Rolls

Application • Rolling mills

- Metal industry

5 Hi Hot Rolling Mills



The 5 Hi Hot Rolling Mills are used to roll down sheets and plates of hard metals and alloys especially of Stainless Steel. We have also successfully supplied these mills for the manufacture of agricultural disk harrow blades. Normally, this mill is used to reduce the thickness of sheets/ plates from a thickness range of about 6-30mm to 1.4mm or above. The time taken to roll down one piece is much less compared to conventional 2Hi mills and this machine is capable of rolling down material to much lower thicknesses.

Features

- Sturdy Mill housings with Liner Plates
- Alloy Steel hardened Back Up Rolls running on Spherical Roller Bearings
- Work Rolls made of Alloy Steel/ Hot Die Steel
- Triple sealing arrangement for Bearings for longer life
- Motorised Screw Down System with Bronze Nut
- Roll Removal Trolley system for easy changing of rolls
- Couplings made of hardened alloy steel
- Hydraulic Roll Lifting (optional)
- Roller Table (optional)

Application • Stainless steel flats and plates

- Plates for Agricultural disk harrow blades
- Flats and plates of harder metals and alloys

REHEATING FURNANCE

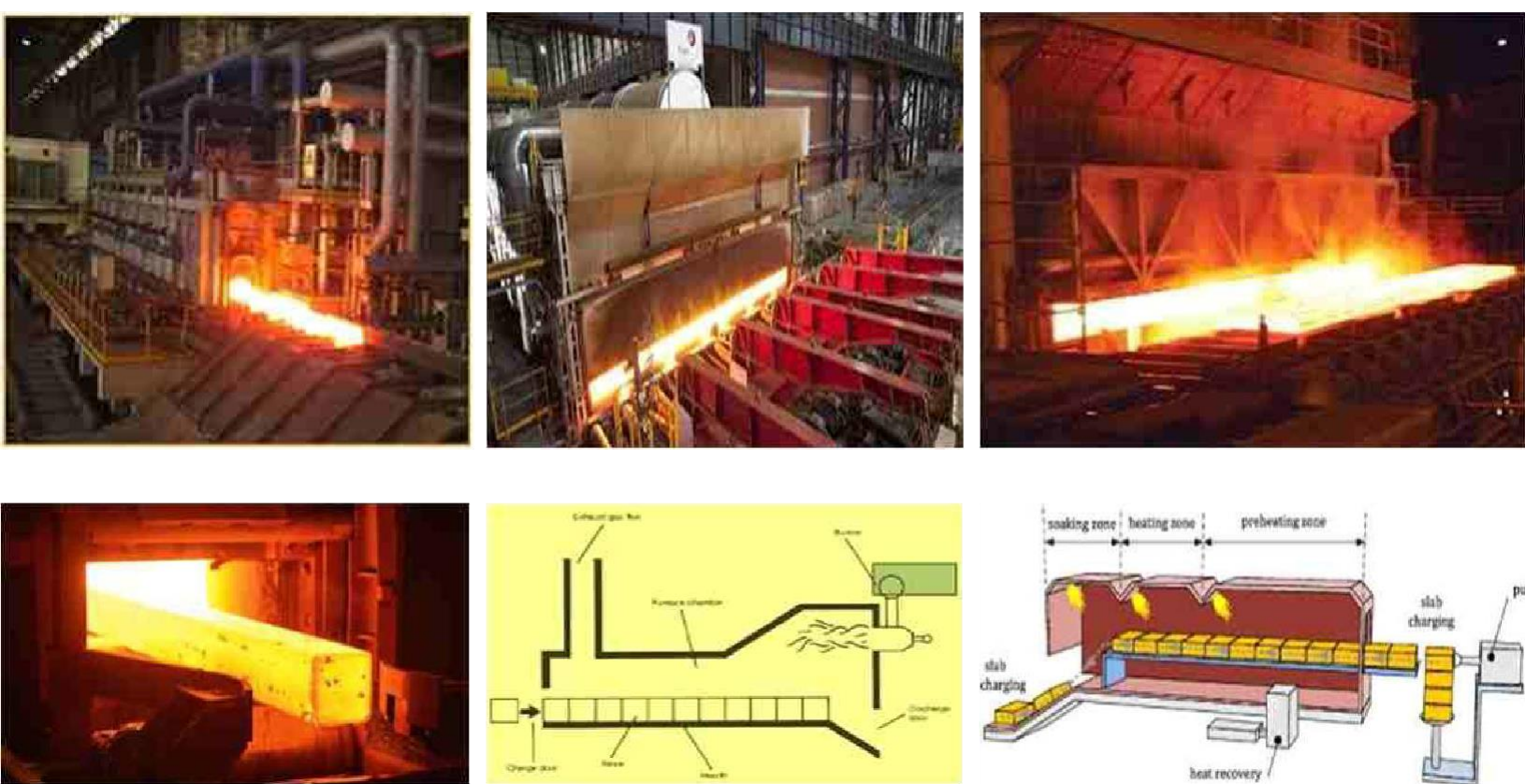

DESCRIPTION

Reheating furnaces are used in hot rolling mills to heat the steel stock (Billets, blooms or slabs) to the rolling temperatures of around 1200 deg C which is suitable for plastic deformation of steel and hence for rolling in the mill. The heating process in a reheating furnace is a continuous process where the steel stock is charged at the furnace entrance, heated in the furnace, and discharged at the furnace exit. Heat is transferred to the steel stock (Fig 1) during its traverse through the furnace mainly by means of convection and radiation from the burner gases and the furnace walls.

Reheating is required during hot rolling of material normally reheating furnace is operated on LDO/FO or CNG Heating the material to a temperature between 600 degrees to 850 degrees centigrade depending on materials.

There is hydraulic pusher provided to push the material inside the furnace material enters from onside and leaves from other end in a hot condition and is ready to feed in the hot rolling mill.

Reheating furnaces are widely used in the Iron and Steel Industry to reheat the semi-finished products like slabs or billets to the rolling temperature at 1250 °C. Reheating furnace is one of the major energy consuming equipment for rolling mills.

2 Hi Hot Rolling Mill Non Reversible Flywheel

The 2Hi Hot Rolling Mills is used for rolling of thick slabs / plate of softer metals like Aluminium, Copper, Brass ci also. We have supplied these Hot Rolling Mills to many Circle industries in India which have been running successfully since many years. We have designed and manufactured mills to take up slab thickness of upto 150 mm and width upto 1270 mm. The normal output thickness of these mail vary from 6 mm to 14 mm after which the material is fed in the Cold rolling Mills for further processing. These mills are normally driven by combination of Gear Box and Coupling Spindle drive but in some cases, the drive can be through open gear and joda gear system to economise the cost.



Features

- Extra heavy duty Gear Box and drive system with Flywheel
- Heavy Duty Mill Housing
- Mechanical Screw Down with Hand wheel
- Material Feeding Guide both side of mill
- Alloy Steel hardened Rolls with long life
- Rolls running on Fibre Bush/ Bearings
- Motorised Screw Down system with Bronze Nut / EN8/EN9
- Motor with Pully

Application

- Aluminum Slabs
- Copper/ Brass slabs
- Mild Steel Plates

WIDER WIDE SLITTING MACHINE

VSR also provides Cut to Length Line solutions in which coil strip of varying widths can be Cut to Lengths according to the desired length requirements.

We provide Cut to Length line for both H.R & C.R Coils with the following range:

The coil strip is pulled by the leveler assembly & fed into the four roll feeder assembly which is equipped with neoprene coated measuring roll coupled with a high resolution encoder to ensure the exact desired strip length is cut with utmost accuracy. Stacker trolley system with the unique design of multiple stackers can be provided for maximum productivity with utmost efficiency by saving on the change over time of the stacks.



AUTOMATIC GAUGE CONTROL

THE MOST ADVANCED AGC IN THE WORLD

DIGI-IMPACT AGC system is setting new standards in the industry by maximizing metal yield. The revolutionary Time-Based AGC is a control algorithm that measures and corrects on a constant time basis typically as often as 3 milli-seconds

The correction rates exceed 350 corrections per meter of material rolled, so it can be up to 3 times more accurate than other AGC systems in use today.



Advantages :

3 times better AGC Performance than other systems

Better overall reduction in thickness deviation

Better response on slow speeds resulting in small coil ends

Reduced tension disturbance during large incoming thickness variations

Reduced high frequency components introduced in to the material ne grained control of roll force cyinders during rolling.

- **Combined mass flow, feed-forward, feedback, elongation and force control modes**
- **Frequency response up to 50 Hz**
- **Fixed 3 millisecond AGC scan time, independent of mill speed and PLC scan time**
- **16 bit analog input resolution for thickness gauges**
- **32 X strip length encoder input interpolation**
- **Dialup access for remote service**
- **HMI software is designed to run under Microsoft Windows 2000/XP**
- **Real time display of material entering and exiting the machine**
- **User configurable report storage and retrieval in Rich Text Format**
- **FFT diagnostic software tool to show deviations caused by out of round rolls, failing drives couplings, tight spots in gearboxes etc.**

NARROW WIDTH SLITTING MACHINE

Our technologically developed Slitting Lines for Metal Coil & Sheets are used for dividing metals of a particular width so they can be used by metal stampers, roll forming and tube producer utilization in production of other types of finished product. These are built to handle a wide array of coils, which ranges from 8 to 84 inches in width. Our range of slitting lines is used for metal coil and sheet to automatically feed the strips into the recoiler clamp without touching the material. We employ the advanced and sophisticated technology which reduces the foundation work to minimal and makes it highly efficient and result oriented.

Coil specifications: Copper coils - 2500kgs x 500 wide x 14.00mm thick

Input Thickness Max*	0.10mm - 6.00mm
Input Width Max*	100mm - 500mm
Coiler Weight Max*	2,500kgs(1.5tones)
Mill speed Max*	80MPM
No. of Slit	as per customer requirement
Maximum inner/outer diameter of the coil	300mm - 350mm - 508mm /1500mm
Minimum Slit Size	5 mm
Depression type	Mechanical Screw Down
Roll bearing lubrication method	Grease lubrication
Line Speed	40 mpm
Electronic control	Siemens
Reducer Gear box	Elecon
Driven	Backup roll Driven
Motor	Siemens / Bharat Bijlee
Total installed capacity	30 kw - 150 kw
Unit size	20m×6m×2m
Line Direction	Left to Right





Features

- Heavily reinforced Stand Housings machined to closest tolerances (Window Size within 0.04 mm)
- All Rolls are made of forged alloy steel having high hardness in range of 62+ HRC
- All Rolls running on Spherical Roller Bearings fitted in C-45 grade steel cast housings
- Motorised worm geared Screw Down with Bronze Nut & Buttress threaded Alloy Steel Screw.
- Extra heavy duty Gear Box & Pinion Stand with hardened output shafts
- Roll removal trolley system for easy replacement of Rolls

Application :-

- Rolling mills • Metal industry

ANNEALING FURNANCE

Pit type annealing furnace is one of the most economical and long serving furnaces. It is also called Pit Pot Annealing furnace. These furnaces have multiple utility and are useful for variety of industries like the Wire Industries, Strips/ Foil Industries, Forging Industries, Casting Industries, Chemical Industries, Fasteners and Bearing Industries too. Even Roll Tempering and Solution annealing can be done in this type of furnace. Pit type furnace is best suited for Low production, Low investment type of factory setup.

A Pit furnace is used for metallurgical processes which required controlled temperatures; mostly used for hardening, tempering, annealing, gas carburizing, decarburizing. Pit furnaces are used to treatment of ferrous and nonferrous metals.

We are into manufacturing of Pit-Pot furnaces of robust quality along with customizable options. With an expertise of over 4 decades. We have a full range of pit type Heat Treatment with a capacity range of 0.2 -1.5 MT for hardening, annealing, normalizing, nitriding, tempering, aging, and stress relieving to offer to industries like Fastener, Bearing, Gears, Rolls, Strip, Wire, Piston rings, aluminum, etc. This type of furnaces can be offered in electrically heated /fuel-fired. Pit furnaces are offered with or without sealed retorts for inert/reducing atmosphere or normal oxidizing atmosphere applications. The furnaces with inert/reducing atmosphere applications will have a facility for introducing atmosphere like hydro- carbon rich gas, ammonia, and nitrogen into a sealed retort made of stainless steel of AISI-310/304 depending on the application temperature. The lid is fitted with gas-tight through a water-cooled neoprene/silicon rubber seal for proper sealing. Hot air circulation inside the furnace is made by an efficient recirculation fan which can be with a two-speed motor or with a VVFD drive.

Our company is the trustworthy manufacturer, exporter, and supplier of Pit Furnace. This device is offered to our customers with protection devices, safety interlocks, and corrosion resistance. Manufactured using heat resistance stainless steel, these furnaces resist distortion and can bear the weight. Pit Furnaces consists of premium quality ceramic fiber insulation to offer energy saving and heating elements for trouble- free operation. The Pit Furnace we offer is very reasonable in price and delivered at the set time frame.

Our furnaces are well equipped with all the necessary add-on facilities needed for the annealing of ferrous and non- ferrous materials. Here is a quick list of some more benefits that you will get from our manufactured furnace.

- ✓ We manufacture a Pit-Pot furnace that can be heated with electricity or fuel. You can opt for your convenient option, and we will design your furnace accordingly.
- ✓ Our manufactured furnace can give you up to 90% of energy efficiency and save your electric bills.
- ✓ Pit-Pot furnaces are quieter than other heating furnaces and are also a cleaner option to go for as they do not emit harmful gasses.



BELL TYPE ANNEALING FURNANCE

The bell furnace belongs to the metallurgic furnaces family.

Their ranking is according to the structure, the metal type or the performed heat treatment but with a common feature: they are built with materials resistant to high temperatures.

Essential in this type of furnaces, these materials are suitable for the heat treatment type performed and an ideal solution for withstanding high temperatures for long periods, without chemical reaction for the charge to be treated, in contact with them during all the process.

For “high temperatures” we mean over 1100°, which can cause problems in case of improper choice of material.

Bell furnaces, in particular, are used to perform heat treatments such as cementation, carbonitriding, quenching, annealing and normalization process.

The structure is composed by :

- base, diffuser and plenum and fan placed between base and diffuser;
- inner cover and inner jacket, the first component with the function of complete covering of the system, the second one for separating the charge area from the heated zone;
- cooling cover, which allows rapid cooling after annealing

process. All this leads to important benefits.

The 4 benefits of the bell furnace and the advantageous experience of Micro in this production

Here below the reasons to choose the bell furnace as an excellent solution :

- 1) Thanks to the protective atmospheres used, the treatments with these furnaces can be carried out on a wide range of materials.
- 2) Thanks to the heating and cooling bells, treatment times are easier.
- 3) Bell furnaces offer a safe and economic method of heat treatment.
- 4) Its structure facilitates quickly the loading of the material to be treated.

Please consider also that Micro can supply the complete group of the structure (base, diffuser, plenum, fan, bell and jacket), manufactured inside the company.



PICKLING LINES (DE-GRESSING LINES) & ACID REGENERATION PLANTS

VSR offers continuous, semi- continuous and push pull pickling lines which provide high quality pickled coils and high productivity for cold rolling. Pickling Lines lines are designed to operate economically, compliant with the environmental norms and optimized pickling process with individual circulation and heating system ensuring minimized consumption of utilities.

Teflon heat exchangers are used in the acid tanks along with used steam condensate for hot water rinsing. The shallow granite pickle tank with counter acid turbulent flow, acid recirculation and spray rinsing ensures superior scale removal and low acid consumption.

VSR offers complete turnkey solutions for setting up acid regeneration plant for the regeneration of acids used in the pickling process of carbon steel. The waste acid generated from pickling lines if discharged in the environment results in high costs and fresh demand for acid.

The units designed by us offer ease of maintenance & efficient operation reducing the carbon footprint of the industry considerably. Acid regeneration not only reduces the long term costs but also optimizes the pickling process due to constant operating parameters.

It is virtually emission free & provides protection to the environment by recovering the hazardous chemical.



STRAIGHTENING MACHINE

This straightening machine shall be taper rolls type and will straighten material flat and edge camber at a time. The strips that shall be possible to be straightened from 10mm x 1.5mm thickness to 300 x 40mm in single stroke. Width in this machine can be set from 10mm to 300mm and thickness from 1.5mm to 40mm. The machine consists of heavy MS fabricated frame and 9 number of rolls, 5 at bottom and 4 on the top. The size adjustment in width and thickness shall be done by worm gear and shaft for easy and fast setting of the machine for a particular size of the totally shall be provided for adjustment of each of the roll according to particular size.

Raw Material :

Simple – copper / Brass / Aluminium - Alloys Strips/Coils

Coil specifications: Copper coils - 5000kgs x 10mm – 300mm wide x 1.50 - 40mm thick

Input Thickness Max*	
Input Thickness Max*	1.5mm-40.0mm
Input Width Max*	10mm~ 300mm
Payoff Weight Max*	5000kgs or Strips
Coiler OD/ID	1000mm/350mm
speed Max*	40MPM (variable)
Driven	9 cardon shaft with pinion stand
Finishing Accuracy	Edge chamber maximum 0.50mm in 1 meter and Flatness shall be within 0.30mm on a surface plate
Depression type	Manual Supported by worm gear and shaft / hydraulic cylinder
Roll bearing lubrication method	Grease lubrication
Stand Rack section	90 × 120
Electronic control	Siemens
Reducer Gear box	Elecon/PBL
Motor	Siemens / Bharat Bijlee
Total installed capacity	As per machine specifications
Unit size	As per machine specifications(L×W×H)



STRAIGHTENING MACHINE WITH CUT TO LENGTH LINE

Cut-to-length (CTL) unrolls and flattens a roll of material, cuts it into sheets of precise length, and stacks the sheets into a bundle. Functions may include, but are not limited to, coil inventory and coil loading, unwinding and unwinding, straightening of the leading edge of the coil, edge trimming, scrap cutting, and sheet stacking. Inline equipment used in the system may vary depending on width, thickness and incoming coil weight, and may include coil storage, uncoilers and coil loading, straighteners, flatteners, roll feeds machines, shears, stackers and related tools and accessories. Depending on the final end product used from the cut sheet, flatness can be a critical point, and a dual leveler, leveler, or stretch leveler can be used in the process.



MULTI-ROLL LEVELLER CUM STRAIGHTENING MACHINES

The Multi-Roll Straightening Machines is utilized for straightening the metal rolls. These machines are sturdily developed from the best grade materials and latest techniques to precisely straighten the roll or coil. The machines are known for their unique attributes like precise roll straightening, sturdy design, energy efficient, long service life, high mechanical strength, high straightening tolerance, excellent performance with two electric motors, improvised productivity, silent operation and suitability with all thickness range.



Features

- Independent roll drives for complete process control
- Optimized roll life
- End to end straightening
- Setting of machine for different tube sizes

Application :-

- Wire Manufacturing Industry
- Metal industry
- Steel Plants



SCALPING MACHINE

Milling Surface

After cooling and winding, the strip blank is straightened by unwinding and straightening machine, and directly enters the milling surface of double-sided copper milling machine, and core-less winding is carried out. The milling thickness is 0.5~0.75mm, the surface of the belt should be flat after milling, and the thickness tolerance is not allowed to be out of tolerance. After milling, the longitudinal thickness deviation of the belt is not more than 0.15mm, the transverse thickness deviation is not more than 0.10mm, and the surface should not have pits, burrs and other defects. The milling machine adopts double frame single milling mode, the equipment is equipped with milling cutter lubrication system and milling chip suction system.

Scalping machine for both surface milling, line speed 3mtr/min with cutter & complete electrical control along with Hydraulic system, variable drive, flattener, pinch Roll and up coiler.

MACHINE DISCRPTION

Scalping machine is use to increase surface finish & to remove oxidized layer from strip / slab cast surface which otherwise create surface defect in finish material after down rolling process.

It is only Bothsurface scalping machine and having 2 No of HSS cutter. 1 mm max. oxide layer is removed from cast surface to be rolled



DRAW BENCH

CHAIN TYPE DRAW BENCHES (FOR STRIPS AND TUBES 100FT LONG)



DESCRIPTION :

Draw Bench used to draw material like rods/strip/sections from conform through a die mounted on face plate the material is pulled by a trolley with a set of grippers to required finished size

HYDRAULIC DRAW BENCHES (UP TO 75 TONNES PULL AND 9METERS LENGTH/AUTOMATIC)



ROLLING MILL ACCESSORIES

WORK ROLL ROLLS



CONTROL PANEL WITH REMOTE DESK



Slitting Cutter



Slitting Spacers





ROLLING MILL PARTS AND ALLIED PRODUCTS

EDGE ROLL UNIT



POWER PACK



ANNEALING POT



CONTROL PANEL WITH REMOTE DESK



REWINDING MACHINE



ROLLING MILL COILER DE-COILER



UP COILER



MANUFACTURING PLANT

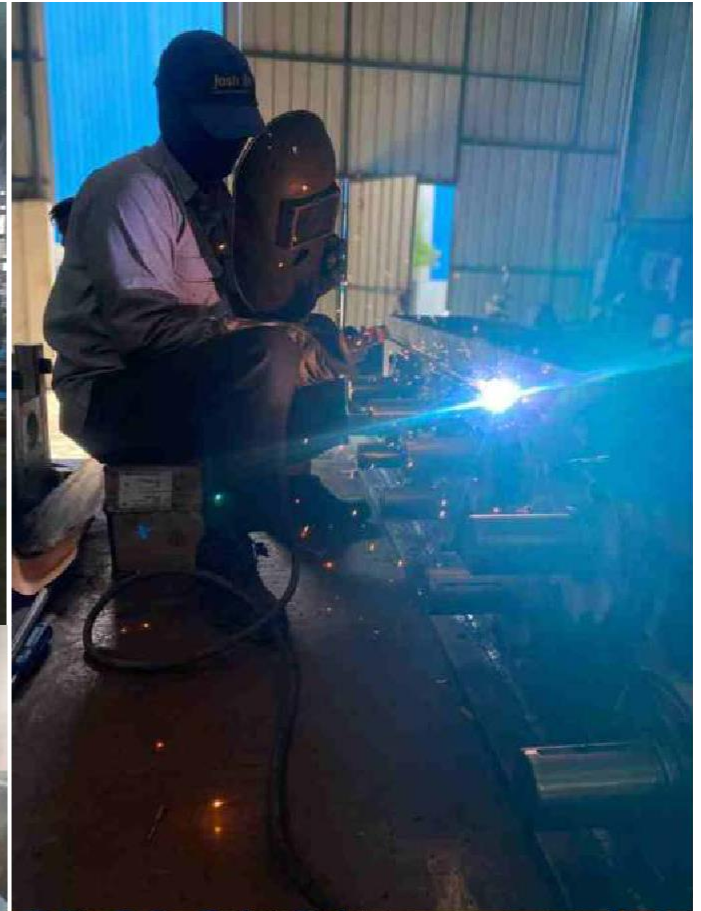

ANNUAL MAINTENANCE CONTRACT (AMC)

At VSR Rolling Mills & Machinery Private Limited, we understand the importance of regular maintenance and upkeep for your machinery and equipment. To ensure smooth and uninterrupted operations, we offer comprehensive Annual Maintenance Contracts (AMCs) tailored to meet your specific needs. Our AMC services cover a wide range of machines and equipment types, providing you with peace of mind and hassle-free maintenance support.

We at VSR Rolling Mills & Machinery Private Limited, always strive to provide comprehensive services and solutions to cater to our clients' diverse needs. With the aim of forward integration of our company, we are pleased to introduce our Annual Maintenance Contract (AMC) services to you.

Our AMC services are aimed at ensuring the smooth and uninterrupted operation of your Copper/Aluminium/Steel Rolling Mill Plants. We understand the importance of timely maintenance of machinery, and our team of experts is committed to providing timely and effective maintenance services to keep your production processes running optimally.

Scope of Services:

- 1. Preventive Maintenance:** Regular inspection, cleaning, and lubrication of machines to prevent potential issues and maximize their performance.
- 2. Breakdown Support:** Prompt response and on-site assistance in case of machine breakdowns to minimize downtime and production losses.
- 3. Repair and Replacement:** Expert repairs and replacement of faulty parts to restore the functionality of the equipment.
- 4. Spare Parts Management:** Timely availability of genuine spare parts to ensure quick repairs and minimize downtime.
- 5. Technical Support:** Professional guidance and technical assistance from our skilled team to address any queries or concerns related to the machines.

FLOW PROCESS CHART

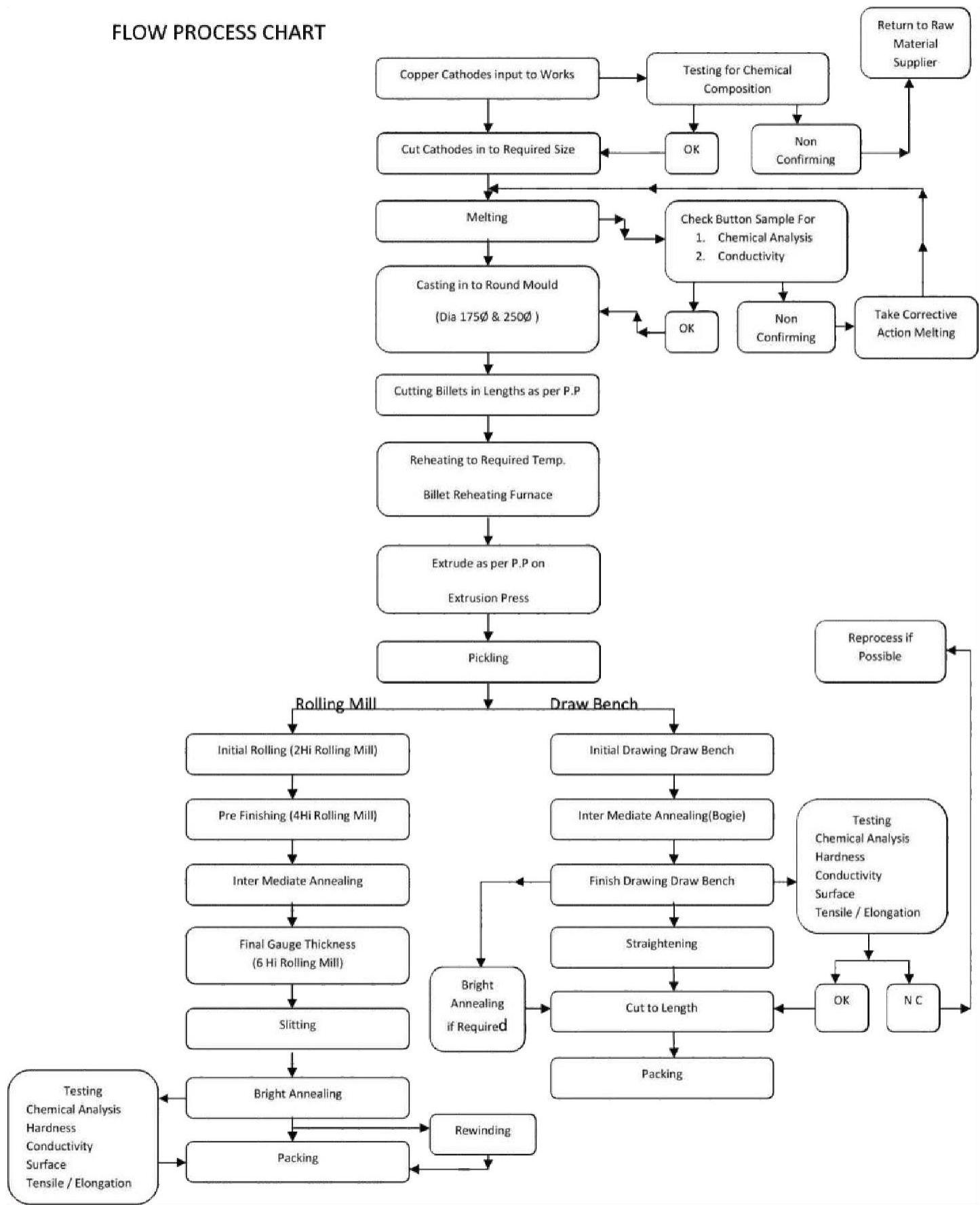

OUR COMPANY'S INFRASTRUCTURE & MACHINES





Vertical Casting Machine



VSR-300, VSR-400, VSR-500
COPPER EXTRUSION MACHINE

Copper Extrusion Machine



Pay Off Bobbin



2 HI Cold Rolling Mill Reversible



4 HI Cold Rolling Mill Reversible



6 HI Cold Rolling Mill Reversible



Slitting Machine

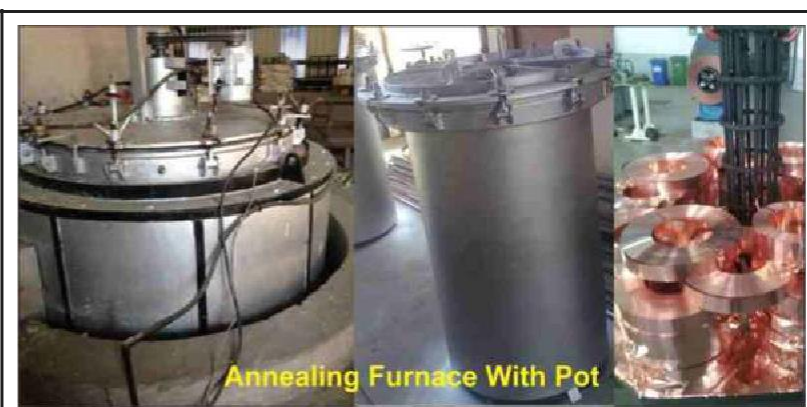

Annealing Furnace With Pot

Annealing Furnace with Pot



Cut to Length



Straightening Machine



Scrap Baling Machine



Hot Rolling Mill

VSR ROLLING MILLS & MACHINERY PVT. LTD.

Mob. : +91 9926030335, +91 9826462019, +91 9588690930

9/1, 9/2, Bardari Behind Aurovindo Hospital, Sanwer Road, Indore Madhya Pradesh (India)

Website : www.vsrrollingmills.com

Email : vsrrollingmills@gmail.com | info@vsrrollingmills.com | ravibankhede@gmail.com